

Technical data sheet

Product features



Multi-function fixed braising pan bowl electric 80

Model	SAP Code	00013569
--------------	-----------------	----------



- Bottom material: Stainless steel - suitable for cooking, easy maintenance
- Bottom thickness: 16.00
- Basin volume [l]: 11
- Usable volume [l]: 11
- Protection of controls: IPX5
- Basin dimensions [mm x mm x mm]: 700 x 510 x 100
- Service accessibility: Trough the frontal panel

SAP Code	00013569	Power electric [kW]	8.000
Net Width [mm]	800	Loading	400 V / 3N - 50 Hz
Net Depth [mm]	600	Bottom material	Stainless steel - suitable for cooking, easy maintenance
Net Height [mm]	280	Basin volume [l]	11
Net Weight [kg]	55.00	Usable volume [l]	11

Technical data sheet

Technical drawing



Multi-function fixed braising pan bowl electric 80

Model

SAP Code

00013569

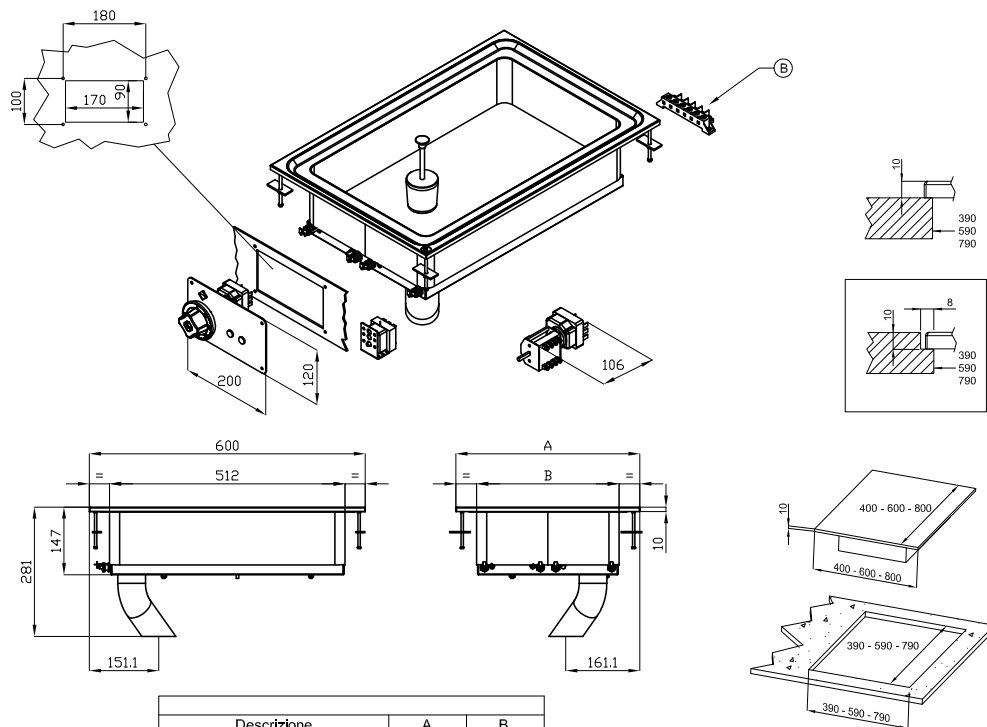

Descrizione	A	B
BRFD-64ET	400 mm	310 mm
BRFD-68ET	800 mm	710 mm

A	Data plate		B	Electrical connection	
---	------------	--	---	-----------------------	--

Technical data sheet

Technical parameters



Multi-function fixed braising pan bowl electric 80

Model

SAP Code

00013569

1. SAP Code:

00013569

2. Net Width [mm]:

800

3. Net Depth [mm]:

600

4. Net Height [mm]:

280

5. Net Weight [kg]:

55.00

6. Gross Width [mm]:

1080

7. Gross depth [mm]:

630

8. Gross Height [mm]:

470

9. Gross Weight [kg]:

65.00

10. Device type:

Electric unit

11. Construction type of device:

Drop-in

12. Power electric [kW]:

8.000

13. Loading:

400 V / 3N - 50 Hz

14. Protection of controls:

IPX5

15. Material:

AISI 304

16. Indicators:

operation and warm-up

17. Basin volume [l]:

11

18. Basin dimensions [mm x mm x mm]:

700 x 510 x 100

19. Maximum device temperature [°C]:

300

20. Minimum device temperature [°C]:

50

21. Power control type:

knob control

22. Service accessibility:

Trough the frontal panel

23. Additional information:

outlet to removable collector in the substructure

24. Bottom thickness:

16.00

25. Bottom material:

Stainless steel - suitable for cooking, easy maintenance

26. Usable volume [l]:

11

Technical data sheet

Technical parameters



Multi-function fixed braising pan bowl electric 80

Model	SAP Code	
		00013569

27. Drain:

Yes

28. Cross-section of conductors CU [mm²]:

1,5

– Výkon (kW): 5-5,7 (230 V); 8,7-9,8 (400 V)